

# TROJAN™

## SIT UP 110 BENCH

MAXIMUM USER  
WEIGHT: 100 KG

ADJUSTABLE  
SEAT LEVEL

STRENGTH  
& TONING



### USER MANUAL



#### CAUTION

READ ALL PRECAUTIONS AND  
INSTRUCTIONS IN THIS MANUAL  
BEFORE USING THIS EQUIPMENT.  
KEEP THIS MANUAL FOR  
FUTURE REFERENCE.

Visit [facebook.com/trojanhealth](https://www.facebook.com/trojanhealth)  
[www.trojanhealth.co.za](http://www.trojanhealth.co.za)  
[www.instagram.com/trojanhealth](https://www.instagram.com/trojanhealth)

# INDEX

- **Important Safety Instructions** \_\_\_\_\_ 3
- **Pre Assembly Check List** \_\_\_\_\_ 5
- **Parts List** \_\_\_\_\_ 6
- **Exploded Drawing** \_\_\_\_\_ 7
- **Assembly Steps** \_\_\_\_\_ 8
- **Exercise Instructions** \_\_\_\_\_ 9
- **Fitness Tips & Techniques** \_\_\_\_\_ 11
- **Conditioning Guidelines** \_\_\_\_\_ 12
- **Warm Up And Cool Down** \_\_\_\_\_ 13
- **Maintenance** \_\_\_\_\_ 14
- **2 Year Limited Warranty** \_\_\_\_\_ 15
- **Repairs Procedure** \_\_\_\_\_ 16

# IMPORTANT SAFETY INSTRUCTIONS

It is the sole responsibility of the purchaser of Trojan products to read the owner's manual, warning labels and instruct all individuals, on proper usage of the equipment. Understanding each and every warning to the fullest is important. If any of these instructions or warnings are unclear please contact Trojan Customer Services on **0861 TROJAN (0861 876526)**, within the Republic of South Africa. Customers residing outside South Africa can contact us on +27 10 206 4405.

The equipment is only intended for home use and is not intended for commercial, institutional and/or studio facilities use.

Contact Trojan with any questions regarding this classification. It is recommended that all users of Trojan be informed of the following information prior to use.



## HEALTH WARNING

---

- Before starting any exercise or conditioning program you should consult with your personal physician to see if you require a complete physical exam. This is especially important if you are inactive, pregnant or suffer from any illness.
- If at any time during exercise you feel faint, dizzy or experience pain, stop exercising immediately and consult your physician.
- To avoid muscular pain and strain, begin each workout by stretching and warming up and end each session by cooling down and stretching.



## PROPER USAGE

---

- Do not use the equipment in any way other than as designed or intended by the manufacturer. It is imperative that Trojan equipment is used properly to avoid injury.
- Injuries may result from exercising improperly or excessively.
- Your Trojan equipment should only be used by 1 person at a time.
- Be careful to maintain your balance while using, mounting, dismounting or assembling your Trojan equipment to avoid injury.
- Servicing other than the procedures in this manual should be performed by an authorised service representative only.
- Use equipment with sufficient space around the equipment so that all exercises can be completed safely. It is recommended that there should be at least 1 m of space around the equipment where access is required to exercise.



## ACCESS CONTROL

---

- Trojan recommends that all fitness equipment be used in a supervised area. It is recommended that the equipment be located in an access controlled area. Control is the responsibility of the owner. Keep children away from all equipment.
- Parents or others supervising adults must provide close supervision of children if the equipment is used in the presence of children.

# IMPORTANT SAFETY INSTRUCTIONS

## INSPECTION

---

- Do not use or permit use of any equipment that is damaged, or has worn or broken parts. For all Trojan equipment use only replacement parts supplied by Trojan.
- Always make sure that all nuts and bolts are tightened prior to each use.
- Maintain labels and nameplates – do not remove labels for any reason. They contain important information.
- Equipment maintenance – preventative maintenance is the key to smooth operating equipment. Please ensure that you follow our maintenance tips to ensure the continued correct function of your Trojan equipment.
- Before any use, examine all accessories approved for use with the Trojan equipment for damage or wear. Should your Trojan equipment appear damaged or worn, do not attempt to use or repair the equipment yourself.
- Please contact our service department on **0861 TROJAN (0861 876526)** to arrange a repair. Customers residing outside South Africa can contact us on +27 10 206 4405.

## OPERATING WARNINGS

---

- It is the purchaser's responsibility to instruct all users as to the proper operating procedures of all Trojan equipment.
- Keep children away from all moving parts. Parents must provide close supervision of children if the equipment is used in the presence of children.
- Do not wear loose fitting clothing or jewellery when using the equipment. It is also recommended that users weights up long hair to avoid contact with moving parts.

## USER WEIGHT LIMITATIONS

---

- This Trojan Sit Up 110 Bench may not be used by persons weighing more than 100 kg.

SAVE THIS INSTRUCTION MANUAL FOR FUTURE USE AND REFERENCE.

If any of these instructions or warnings are unclear please contact Trojan Customer Services on **0861 TROJAN (0861 876526)** within the Republic of South Africa or **visit [www.trojanhealth.co.za](http://www.trojanhealth.co.za)**. Customers residing outside South Africa can contact us on +27 10 206 4405.

# PRE ASSEMBLY CHECK LIST

Thank you for choosing the Trojan Sit Up 110 Bench. We take great pride in producing this quality product and hope it will provide many hours of quality exercise to make you feel better, look better and enjoy life to its fullest.

Yes, it's a proven fact that a regular exercise program can improve your physical and mental health. Too often, our busy lifestyles limit our time and opportunity to exercise. The Trojan Sit Up 110 Bench provides a convenient and simple method to begin your assault on getting your body in shape and achieving a healthier lifestyle.

Before reading further, please review the drawing below and familiarize yourself with the parts that are labeled.

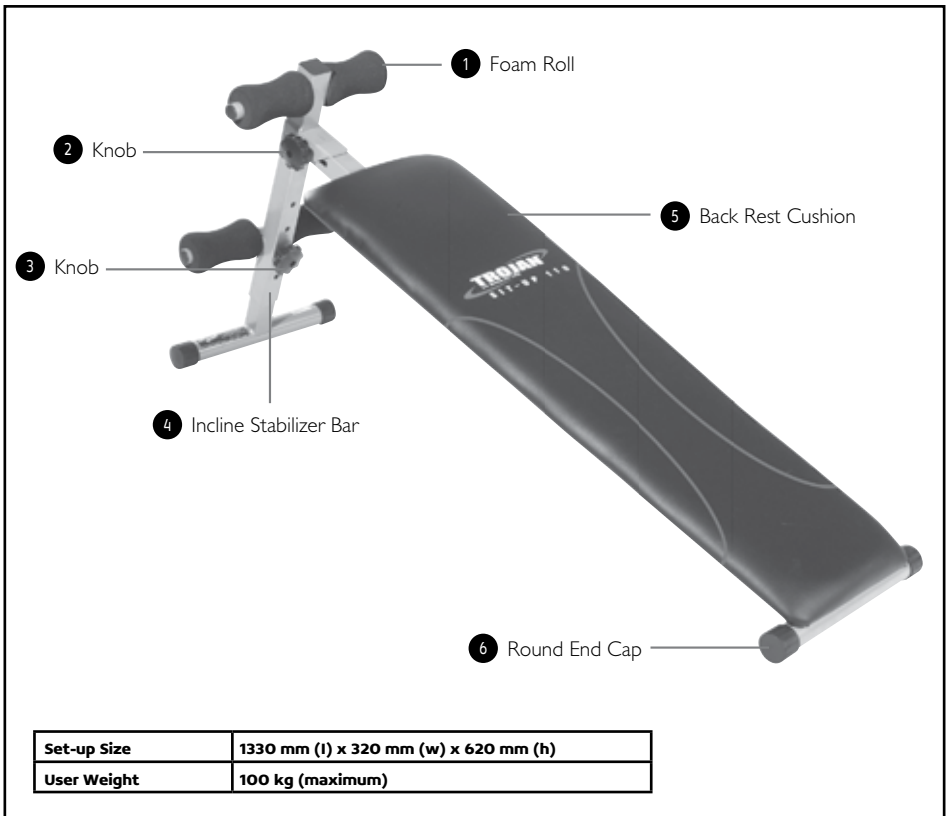

# PARTS LIST

No.	Description	Qty
1	Main Frame	1
2	Back Rest	1
3	Back Rest Mounting Hardware	4
4	Support Leg	1
5	Incline Stabiliser Bar	1
6	Washer (3/8" x 19 mm)	1
7	Knob	2
8	Hex Bolt (3/8" x 2-1/4")	2
9	Upper Crossbar	1
10	Adjustment Crossbar	1
11	Foam Roll	4
12	Round Cap (1")	4
13	Round End Cap (38 mm)	4

**NOTE:**

The parts mentioned above are all the parts you need to assemble this equipment. Before you start to assemble, please check the hardware packing to make sure all parts are included. Basic tools, such as spanners will be required for assembly.

# EXPLODED DRAWING

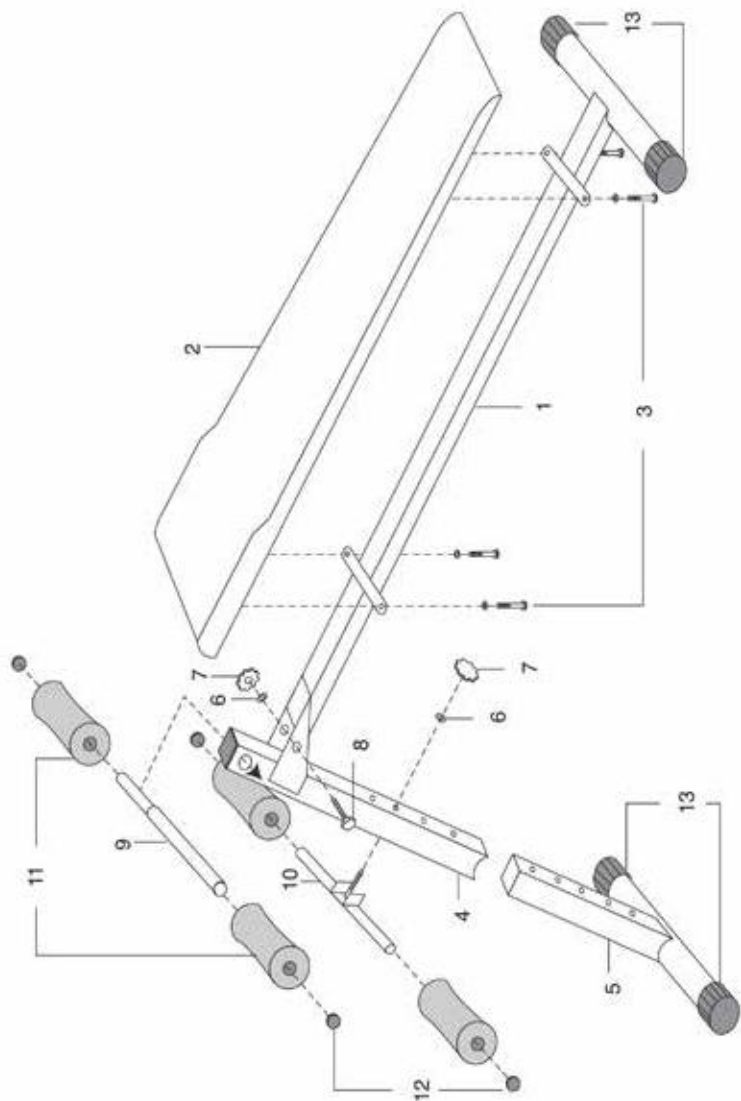

# ASSEMBLY STEPS

## 1. PREPARATION

- Before assembling make sure that you will have enough space around the item.
- Use the supplied parts and hardware for the assembly.
- Before assembling please check whether all the required parts have been supplied as per the parts list.

### STEP 1: BACK REST ASSEMBLY

Fasten Back Rest (2) to Main Frame (1) with the 4 Back Rest Mounting Hardware (3).

### STEP 2: SUPPORT LEG ASSEMBLY

Connect Support Leg (4) to Main Frame (1) with 1 Hex Bolt (3/8" x 2-1/4") (8), Washer (3/8" x 19 mm) (6) and Knob (7).

### STEP 3: INCLINE STABILISER ASSEMBLY

Slide Incline Stabiliser Bar (5) into Support Leg (4). Fasten with Adjustment Crossbar (10) at desired height and tighten with Washer (3/8" x 19 mm) (6) and Knob (7).

### STEP 4: FOAM ROLL ASSEMBLY

Slide Foam Roll (11) onto Adjustment Crossbar (10).

### STEP 5: UPPER CROSSBAR ASSEMBLY

Slide Upper Crossbar (9) through Support Leg (4).

Slide 1 Round Cap (12) on Upper Crossbar (9) on either side of Support Leg (4).

### STEP 6: FOAM ROLL ASSEMBLY

Attach Foam Roll (11) on Upper Crossbar (9) and Adjustment Crossbar (10).

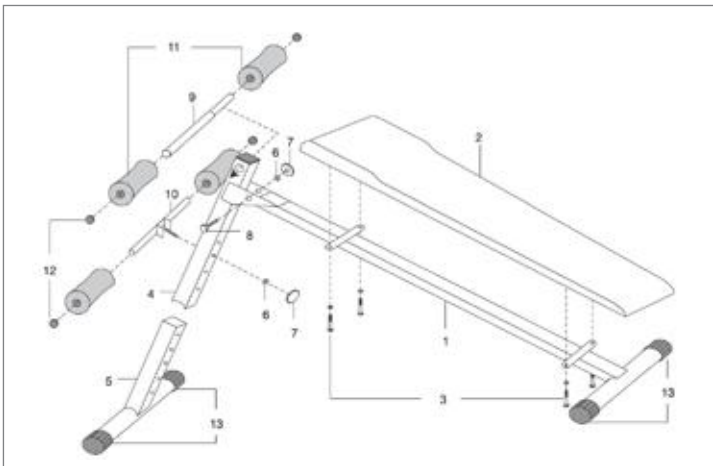



# EXERCISE INSTRUCTIONS

Using your Trojan Sit Up 110 Bench provides you with several benefits, it will improve your physical fitness, tone muscle and in conjunction with a calorie controlled diet, help you lose weight.

## THE WARM UP PHASE

This stage helps get the blood flowing around the body and the muscles working properly. It will also reduce the risk of cramp and muscle injury. It is advisable to do a few stretching exercises as shown below. Each stretch should be held for approximately 30 seconds, do not force or jerk your muscles into a stretch. If it hurts, **STOP**.

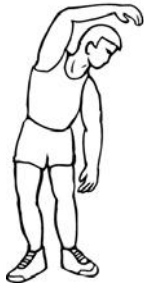

SIDE BENDS



FORWARD BENDS



OUTER THIGH



INNER THIGH

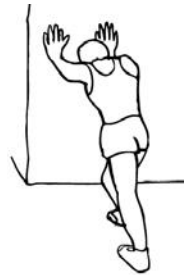

CALF STRETCH

This is the stage where you put the effort in. After regular use, the muscles in your body will become stronger. Work at your own pace, but it is very important to maintain a steady tempo throughout. The rate of work should be sufficient to raise your heart beat into the target zone shown on the graph below.

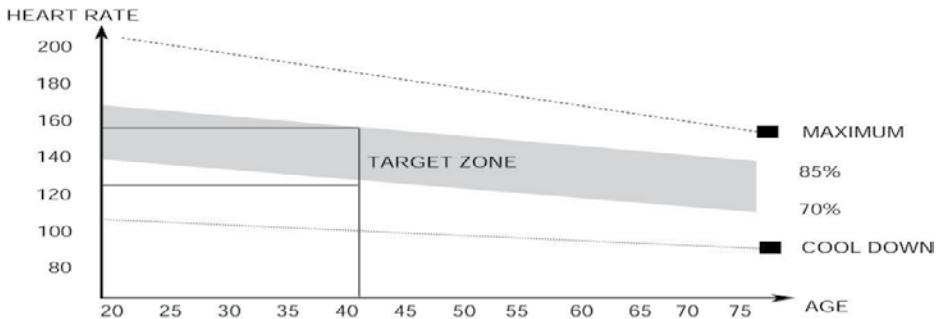

# EXERCISE INSTRUCTIONS

This stage is to let your Cardiovascular System and muscles wind down. This is a repeat of the warm up exercise i.e. reduce your tempo, continue for approximately 5 minutes. The stretching exercises should now be repeated, again remembering not to force or jerk your muscles into the stretch.

As you get fitter you may need to train longer and harder. It is advisable to train at least 3 times a week, and if possible space your workouts evenly throughout the week.

## **MUSCLE TONING**

To tone muscle while on your Trojan Sit Up 110 Bench you will need to use heavy weights. This will put more strain on your muscles and may mean you cannot train for as long as you would like. If you are also trying to improve your fitness, you need to alter your training program. You should train as normal during the warm up and cool down phases, but towards the end of the exercise phase you should increase resistance, making your legs work harder than normal. You may have to reduce your speed to keep your heart rate in the target muscles.

## **WEIGHT LOSS**

The important factor here is the amount of effort you put in. The harder and longer you work the more calories you will burn.

# FITNESS TIPS & TECHNIQUES

## AEROBIC EXERCISE

Aerobic exercise is any sustained activity that sends oxygen to your muscles via your heart and lungs. Aerobic exercise improves the fitness of your lungs and heart – your body’s most important muscle. Aerobic exercise fitness is promoted by any activity that uses your large muscles (arms, legs, or buttocks, for example). Your heart beats quickly and you breathe deeply. An aerobic exercise should form part of your entire exercise routine.

## WEIGHT TRAINING

Along with aerobic exercising which helps get rid of and keep off the excess fat that our bodies can store, weight training is an essential part of the exercise routine process. Weight training helps tone, build and strengthen muscle. If you are working above your target zone, you may want to do a lesser amount of reps. Always consult your physician before beginning any exercise program.

## MUSCLE CHART

The exercise routine that is performed when using the Trojan Sit Up 110 Bench with dumbbells will develop the whole body as well as condition the circulatory system and provide a good aerobic workout. These muscle groups are highlighted on the muscle chart below.

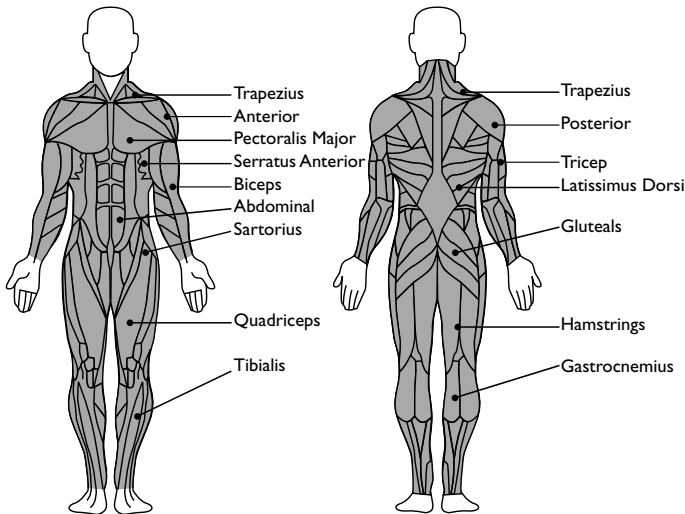

**VISIT:**

[www.trojanhealth.co.za](http://www.trojanhealth.co.za) for equipment choices and exercise programs

# CONDITIONING GUIDELINES

How you begin your exercise program depends on your physical condition. If you have been inactive for several years, or are severely overweight, you must start slowly and increase your time on the equipment, a few minutes per workout.

Initially, you may be able to exercise only for a few minutes in your target zone, however, your aerobic fitness will improve over the next 6 to 8 weeks. Don't be discouraged if it takes longer. It's important to work at your own pace. Ultimately, you'll be able to exercise continuously for 30 minutes. The better your aerobic fitness, the harder you will have to work to stay in your target zone. Please remember these essentials:

- Have your doctor review your training and diet programs to advise you of a workout routine you should adopt.
- Begin your training program slowly with realistic goals that have been set by you and your doctor.
- Monitor your pulse frequently.
- Establish your target heart rate based on your age and condition.

## EXERCISE INTENSITY

To maximise the benefits of exercising, it is important to exercise with the proper intensity. The proper intensity level can be found by using your heart rate as a guide. For effective aerobic exercise, your heart rate should be maintained at a level between 65% and 85% of your maximum heart rate as you exercise. This is known as your target zone. You can find your target zone in the table below.

During the first few months of your exercise program, keep your heart rate near the low end of your target zone as you exercise. After a few months, your heart rate can be increased gradually until it is near the middle of your target zone as you exercise.

To measure your heart rate, stop exercising but continue moving your legs or walking around and place 2 fingers on your wrist. Take a 6 second heartbeat count and multiply the results by 10 to find your heart rate. For example, if your 6 second heartbeat count is 14, your heart rate is 140 beats per minute. (A 6 second count is used because your heart rate will drop rapidly when you stop exercising).

Adjust the intensity of your exercise until your heart rate is at the proper level.

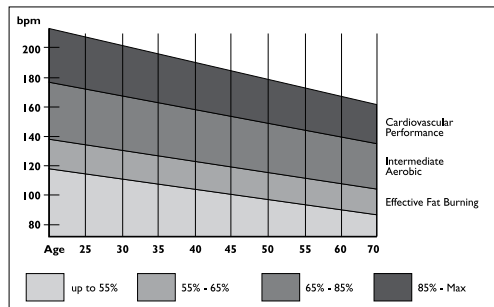
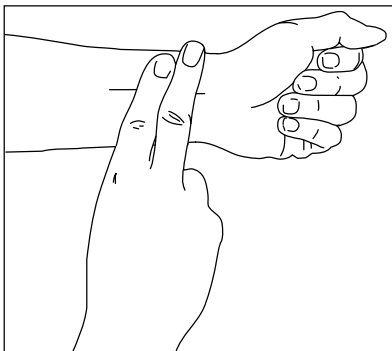

For more information visit:

[www.trojanhealth.co.za](http://www.trojanhealth.co.za)

# WARM UP & COOL DOWN

## WORKOUT GUIDELINES

Each workout should include the following 3 parts:

- 1. A WARM-UP:** 5 to 10 minutes of stretching and light exercise. A proper warm-up increases your body temperature, heart rate, and circulation in preparation for exercise.
- 2. TRAINING ZONE EXERCISE:** 20 to 30 minutes of exercising with your heart rate in your training zone. (Note: During the first few weeks of your exercise program, do not keep your heart rate in your training zone for longer than 20 minutes).
- 3. COOL-DOWN:** 5 to 10 minutes of stretching. This will increase the flexibility of your muscles and will help to prevent post-exercise problems.

## EXERCISE FREQUENCY

To maintain or improve your condition, plan 3 workouts each week, with at least 1 day of rest between workouts. After a few months of regular exercise, you may complete up to 5 workouts each week, if desired. Remember, the key to success is to make exercise a regular and enjoyable part of your everyday life.

## SUGGESTED STRETCHES

The correct form for several basic stretches are shown on the right. Move slowly as you stretch, hold the position and never bounce.

### 1. TOE TOUCH STRETCH

Stand with your knees bent slightly and slowly bend forward from your hips. Allow your back and shoulders to relax as you reach down toward your toes as far as possible. Hold for 15 counts, and then relax. Repeat 3 times.

**Stretches:** Hamstrings, back of knees and back.

### 2. HAMSTRING STRETCH

Sit with 1 leg extended. Bring the sole of the opposite foot toward you and rest it against the inner thigh of your extended leg. Reach toward your toes as far as possible. Hold for 15 counts, and then relax. Repeat 3 times for each leg.

**Stretches:** Hamstrings, lower back and groin.

### 3. CALF/ACHILLES STRETCH

With 1 leg in front of the other, reach forward and place your hands against a wall. Keep your back leg straight and your back foot flat on the floor. Bend your front leg, lean forward and move your hips toward the wall. Hold for 15 counts, and then relax. Repeat 3 times for each leg. To cause further stretching of the Achilles tendons, bend your back leg as well.

**Stretches:** Calves, Achilles tendons and ankles.

### 4. QUADRICEPS STRETCH

With 1 hand against a wall for balance, reach back and grasp 1 foot with your other hand. Bring your heel as close to your buttocks as possible. Hold for 15 counts, then relax. Repeat 3 times for each leg.

**Stretches:** Quadriceps and hip muscles.

### 5. INNER THIGH STRETCH

Sit with the soles of your feet together and your knees outward. Pull your feet toward your groin area as far as possible. Hold for 15 counts, and then relax. Repeat 3 times.

**Stretches:** Quadriceps and hip muscles.



# MAINTENANCE

## **CLEANING**

The Trojan Sit Up 110 Bench can be cleaned with a soft cloth and mild detergent. Do not use abrasives or solvents on plastic parts.

## **STORAGE**

Keep the Trojan Sit Up 110 Bench in a clean and dry environment away from children.

# 2 YEAR LIMITED WARRANTY

The Manufacturer hereby provides a warranty to the original purchaser of this product ('the Consumer') that this product will be free of manufacturing defects in materials and workmanship which under normal, personal, family or household use (commercial use expressly excluded) manifest themselves within the 2 years from the date of purchase.

## EXCLUSIONS

- The warranty does not include and will not be construed to cover products damaged as a result of disaster, misuse, commercial use, not in accordance with the written instructions included with the product, abuse and/or any non-authorized modification of the product, incorrect installation of the product or normal wear and tear.
- All demo models carry a 3 month warranty.

## WAIVER

The warranty and the obligations of the Manufacturer provided herein are in lieu of, and the Consumer, waives all other warranties, guarantees, conditions or liabilities, express or implied, arising by law or otherwise, including without limitation, any obligation of the Manufacturer in respect of any injury, loss or damage (direct, indirect or consequential) arising out of the use of, or inability to use this product and whether or not occasioned by the Manufacturer's negligence or any act or omission on its part.

## PROOF OF PURCHASE

Any claim in terms of the warranty must be supported by a proof of purchase or a warranty number. Warranty numbers can be issued through contacting our Trojan Call Centre on 0861 Trojan (0861 876526) or online at [www.trojanhealth.co.za](http://www.trojanhealth.co.za). Customers residing outside South Africa can contact us on +27 10 206 4405. If such proof is not available, then notwithstanding anything to the contrary herein, the service agent's prevailing charges for services/repairs including call out and/or spares will be payable by the Consumer upon collection or delivery of the repaired product.

The Consumer does not need to return the product to the store. The Consumer should call the Trojan Call Centre on 0861 Trojan (0861 876526). Customers residing outside South Africa can contact us on +27 10 206 4405 and the call centre will advise of the procedure. During the warranty period the product may only be serviced and/or repaired by the Manufacturer's duly authorised agent(s).

<b>TROJAN</b>	ATTACH RECEIPT
<b>CLIENT DETAILS</b>	
NAME: _____	
EMAIL: _____	CELL: _____
TEL(H): _____	TEL(W): _____ FAX: _____
ADDRESS: _____	
_____	
<b>PRODUCT DETAILS</b>	
DATE OF PURCHASE: dd / mm / yy	SERIAL NUMBER: _____ TILL SLIP NUMBER: _____
DESCRIPTION OF PURCHASE: _____	
_____	
<b>BRANCH PURCHASED AT</b>	
_____	
_____	
<b>0861 TROJAN (0861 876526) / +27 10 206 4405</b>	<b>WWW.TROJANHEALTH.CO.ZA</b>

# REPAIRS PROCEDURE

Should you experience any faults or breakdowns on your Trojan equipment, please adhere to the following procedure to have the fault rectified speedily and professionally.

Do not return the product to the store.

Call the Trojan Call Centre on 0861 Trojan (0861 876526) to log the faulty product (under warranty or out of warranty). Customers residing outside South Africa can contact us on +27 10 206 4405.

The operator or technical advisor will try identify the fault, and will book a service team call out.

The service team will endeavour to fix the problem in your home on an agreed date and time.

Only if the fault cannot be repaired in the convenience of your home, will the service team take the faulty product back to the service centre.

Items repaired in our service centre will be returned to your home on an agreed date and time.

**Note:** Should you live in an outlying area or outside South Africa, it may be necessary to return the product to the store nearest to you. Our service operator will advise you of your repair procedure.

## COST OF REPAIRS

### UNDER WARRANTY

Any items still under warranty will be repaired free of charge, as long as it complies with the terms and conditions of the warranty (refer to “warranties” section in this manual). Any items that need to be repaired that are NOT covered in the warranty will be for the Consumer’s expense. A quote for the repair/replacement of these items will be provided to the Consumer for approval prior to repairs being conducted.

### OUT OF WARRANTY

Any items that need to be repaired once the warranty has expired will be for the Consumer’s expense including call out fees.

A quote for the repair/replacement of these items will be provided to the Consumer for approval prior to repairs being conducted.

**2 YEAR  
WARRANTY**

If this product proves to be faulty during normal use due to defective materials or workmanship. Refer to user manual or website for terms and conditions.

0861 876 526  
**0861 TROJAN**  
**+27 10 206 4405**

Please call us for any product queries, after sales support, repairs or installations.

Manufactured for Masstores (Pty) Ltd.  
16 Peltier Drive, Sunninghill, Ext 6, Sandton, 2146, South Africa.  
**MADE IN CHINA**

Always consult a physician before starting a new exercise routine

Use in conjunction with a healthy eating plan

Only use product for its intended purpose to prevent injury

Visit [facebook.com/trojanhealth](https://facebook.com/trojanhealth)  
[www.trojanhealth.co.za](http://www.trojanhealth.co.za)  
[www.instagram.com/trojanhealth](https://www.instagram.com/trojanhealth)

Like us on  
**facebook**

#18M11T030